

# Grófar lamir PN

## Grindarlamir einfaldar



Art. nr.	Pakning	Overflade	A mm	B mm	Dim.	Tap	Skrue bolt	Stk. pr. pk.
201000107	KP	varmforzinket	300	25	6	11	6/8	1
201200107	KP	varmforzinket	400	25	6	11	6/8	1
202100107	KP	varmforzinket	400	40	6	13	6/10	1
202200107	KP	varmforzinket	500	40	6	13	6/10	1
202300107	KP	varmforzinket	600	40	6	13	6/10	1
202400107	KP	varmforzinket	700	40	6	13	6/10	1

## Grindarlamir tvöfaldar

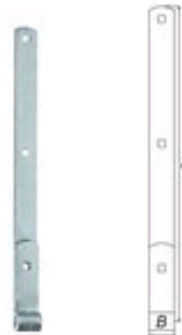

Art. nr.	Pakning	Overflade	A mm	B mm	Dim.	Tap	Skrue bolt	Stk. pr. pk.
208200107	KP	varmforzinket	500	40	6	16	10	1
208400107	KP	varmforzinket	600	40	6	16	10	1
209100107	KP	varmforzinket	750	45	8	19	10	1
209200107	KP	varmforzinket	900	45	8	19	10	1
209300107	KP	varmforzinket	1100	45	8	19	10	1

## Stafar án plötu

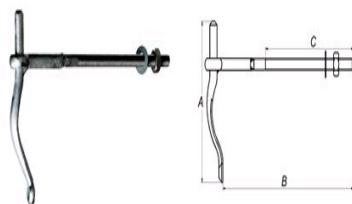

Art. nr.	Pakning	Overflade	A mm	B mm	C mm	Dim.	Tap	Stk. pr. pk.
211200107	KP	varmforzinket	135	200	135	10	11	1
212200107	KP	varmforzinket	145	200	135	10	13	1
213200107	KP	varmforzinket	175	265	183	12	16	1
214200107	KP	varmforzinket	198	270	170	12	19	1

## Staflar með plötu

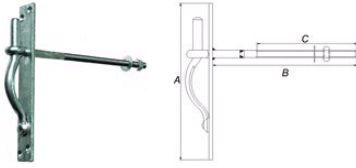

Art. nr.	Pakning	Overflade	A mm	B mm	C mm	Dim.	Tap	Skrue bolt	Stk. pr. pk.
212300107	KP	varmforzinket	210	195	135	30x5	13	5,5	1
213300107	KP	varmforzinket	245	245	173	40x5	16	5,5	1
214300107	KP	varmforzinket	245	345	245	40x5	19	5,5	1

## Staflamir Heitgalv.

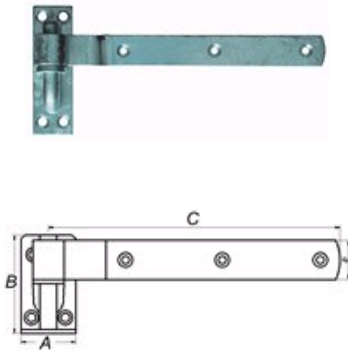

Art. nr.	Pakning	Overflade	A mm	B mm	C mm	D mm	Tap	Skrue bolt	Sæt pr. enh.	Sæt pr. pk.
222100101	SB	varmforzinket	42	75	223	30	13	5	2	1
222100109	KP	varmforzinket	42	75	223	30	13	5	2	1
222200101	SB	varmforzinket	42	75	293	30	13	5	2	1
222200109	KP	varmforzinket	42	75	293	30	13	5	2	1
222300101	SB	varmforzinket	42	75	373	30	13	5	2	1
222300109	KP	varmforzinket	42	75	373	30	13	5	2	1
222400101	SB	varmforzinket	42	75	453	30	13	5	2	1
222400109	KP	varmforzinket	42	75	453	30	13	5	2	1
222500101	SB	varmforzinket	42	75	608	30	13	5	2	1
222500109	KP	varmforzinket	42	75	608	30	13	5	2	1

## Staflamir Skraut Heitgalv

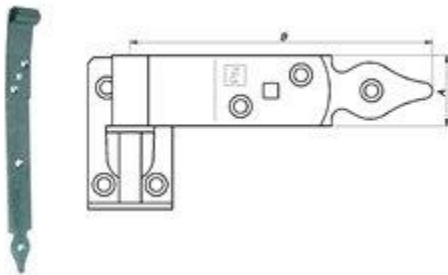

Art. nr.	Pakning	Overflade	A mm	B mm	Dim.	Tap	Skrue bolt	Sæt pr. enh.
223000109	KP	varmforzinket	35	150	3	11	5	2
223100109	KP	varmforzinket	35	200	3	11	5	2
223200109	KP	varmforzinket	35	300	3	11	5	2
223300109	KP	varmforzinket	35	400	3	11	5	2
223400109	KP	varmforzinket	35	500	3	11	5	2
223500109	KP	varmforzinket	35	600	3	11	5	2

## Plötustaflar

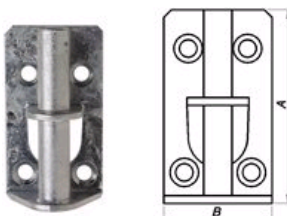

Art. nr.	Pakning	Overflade	A mm	B mm	Dim.	Tap	Skrue bolt	Stk. pr. pk.
224600107	KP	varmforzinket	75	42	3	13	5	1

## Upphengi m/stálhjól



Art. nr.	Pakning	Overflade	A mm	B mm	C mm	Dim.	Skrue bolt	Stk. pr. pk.
240200107	KP	varmforzinket	245	26	50	4	5/10	1
240300107	KP	varmforzinket	315	30	60	6	5,5/10	1
240400107	KP	varmforzinket	400	30	75	6	5,5/10	1
240500107	KP	varmforzinket	455	40	90	8	5,5/10	1
240600107	KP	varmforzinket	500	45	105	8	6/10	1

## Upphengi með plasthjól

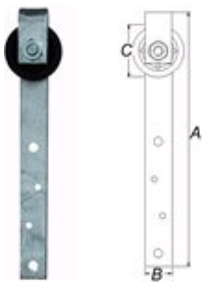

Art. nr.	Pakning	Overflade	A mm	B mm	C mm	Dim.	Skrue bolt	Stk. pr. pk.
243200107	KP	varmforzinket	245	26	50	4	5/10	1
243300107	KP	varmforzinket	315	30	60	6	5,5/10	1
243400107	KP	varmforzinket	400	30	75	6	5,5/10	1

## Plasthjól fyrir hurð

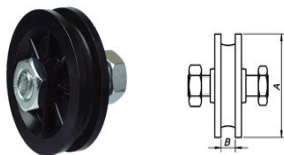

Art. nr.	Pakning	Overflade	A mm	B mm	Skrue bolt	Stk. pr. pk.
244209027	KP	sort plast	50	8	10	1
244309027	KP	sort plast	60	8	10	1
244409027	KP	sort plast	75	10	10	1

## Stýrirúlla f/rennihurð

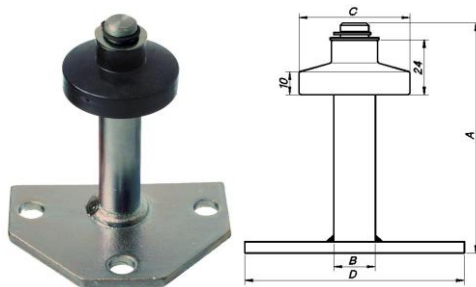

Vörunúmer: **252500307**

## Stálhjól f/hurð m.bolta

Art.nr.	EAN nr.	TUN nr.	Nobb	Tekst
241200007	5701984105686	1656446	23039381	STØBEJERNSRULLE M/BOLT 50MM

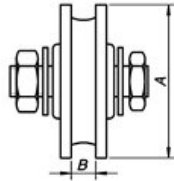

50mm. Vörunúmer: 241200007

60mm. Vörunúmer: 241300007

75mm. Vörunúmer: 241400007

## Staflamir Design 39cm (par)

Art. nr.	Pakning	Overflade	A mm	B mm	Tap	Skrue bolt
221702211	SB	Grá Detal Seal	42	78,5	13	5
221702221	SB	Sort Delta Seal	42	78,5	13	5

Grá  
Svört

221702211  
221702221

